

## Mock Up Entrance Examination Test

**Question 1**

Not yet answered

Marked out of  
1.00

When two non-intersecting and non-coplaner shafts are connected by gears, the arrangement is known as:

Select one:

- a. spiral gearing
- b. helical gearing
- c. spur gearing
- d. bevel gearing

### Question 1

*When two non-intersecting and non-coplaner shafts are connected by gears, the arrangement is known as:*

- a. spiral gearing
- b. helical gearing
- c. spur gearing
- d. bevel gearing

### Question 2

*Screws used for power transmission should have:*

- a. very fine threads
- b. high efficiency
- c. strong teeth
- d. low efficiency

### Question 3

*Pressure angle of involute teeth gear means:*

- a. angle between axes
- b. angle of contact head circle
- c. angle between the tooth face and the gear wheel tangent
- d. normal angle of contact

### Question 4

*Which of the following states of stress is typical of the static tensile test?*

- a. pure shear
- b. biaxial stretching
- c. uniaxial compression
- d. uniaxial tension

### Question 5

*Iron-carbon alloys containing 2.14 to 4.3% carbon are known as:*

- a. hypo-eutectic cast irons
- b. hyper-eutectic cast irons
- c. eutectic cast irons
- d. steels

Question 6

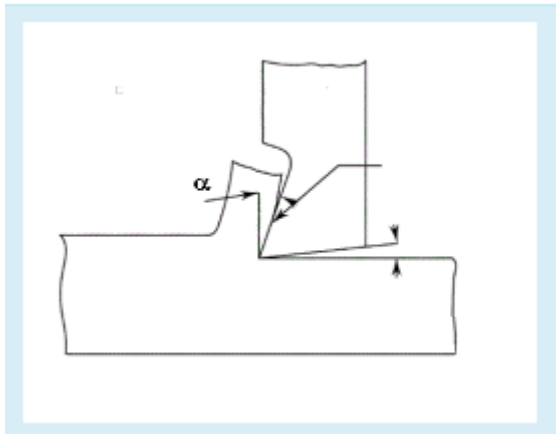

The angle  $\alpha$  in the Fig. above is termed as:

- a. back rake angle
- b. side relief angle
- c. side clearance angle
- d. front clearance angle

Question 7

Broaching tools are not used in piece production because:

- a. the productivity of these tools is low
- b. tool adjustment takes a long time
- c. price of the tool is high
- d. sharpening blunted tools is difficult

Question 8

There is a foundry mould shown in the Fig. Position 6 represents:

- a. cope
- b. riser
- c. parting line
- d. drag

Question 9

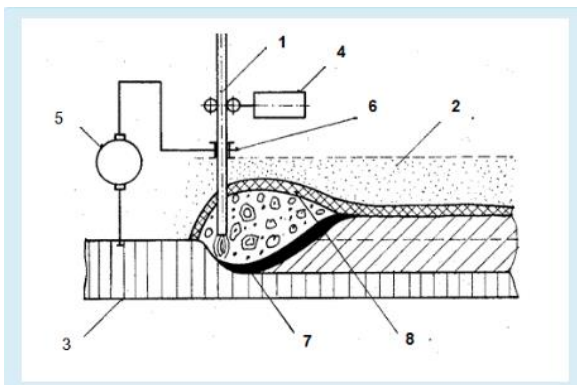

What type of welding method is shown in this Figure?

- a. Gas tungsten arc welding (TIG)
- b. Shielded metal arc welding
- c. Gas metal arc welding (MIG)
- d. Submerged Arc Welding (SAW)

Question 10

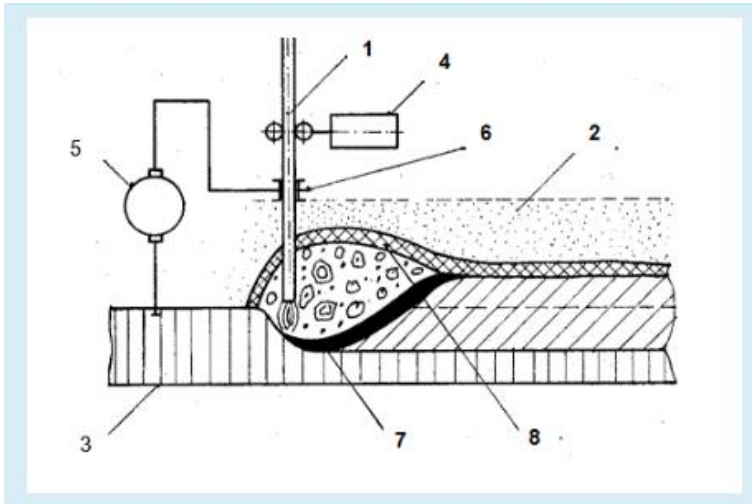

Position 8 in the Fig. represents:

- a. electrode
- b. contact die
- c. base material
- d. feed arrangement (device, drum)

Question 11

The Fig. below shows a stress-strain curve which was measured by means of the static tensile test. Point B represents:

- a. ductility
- b. ultimate tensile strength
- c. yield strength
- d. stiffness

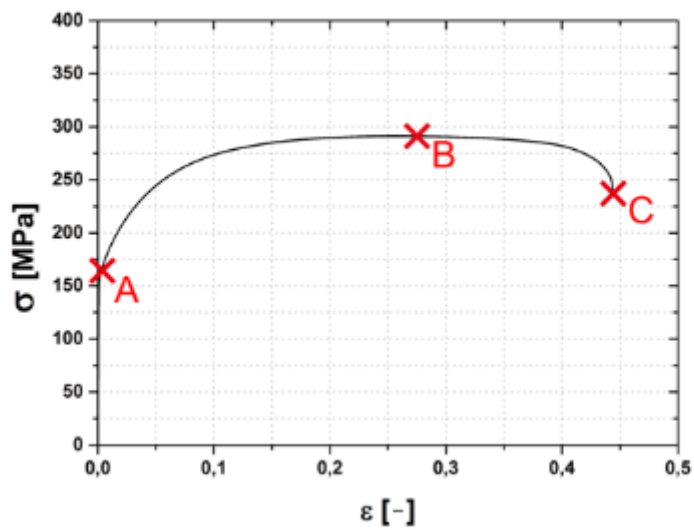

Question 12

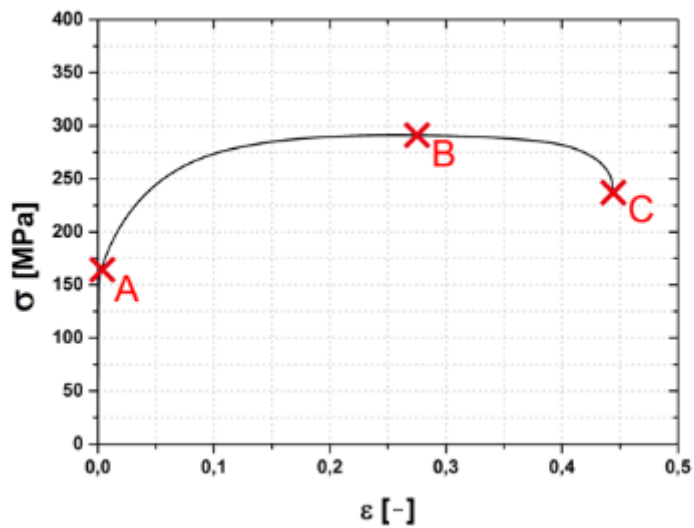

According to the shape of the given stress-strain curve (see Figure) it is evident that this diagram is termed as:

- load – extension diagram
- engineering diagram
- working (registration) diagram
- true diagram

Question 13

There is an injection molding machine shown in the Figure. Position 1 represents:

- base / frame
- injection unit
- clamping unit
- control unit

